

BUSINESS  
ANSWERS IN  
BLACK AND  
WHITE

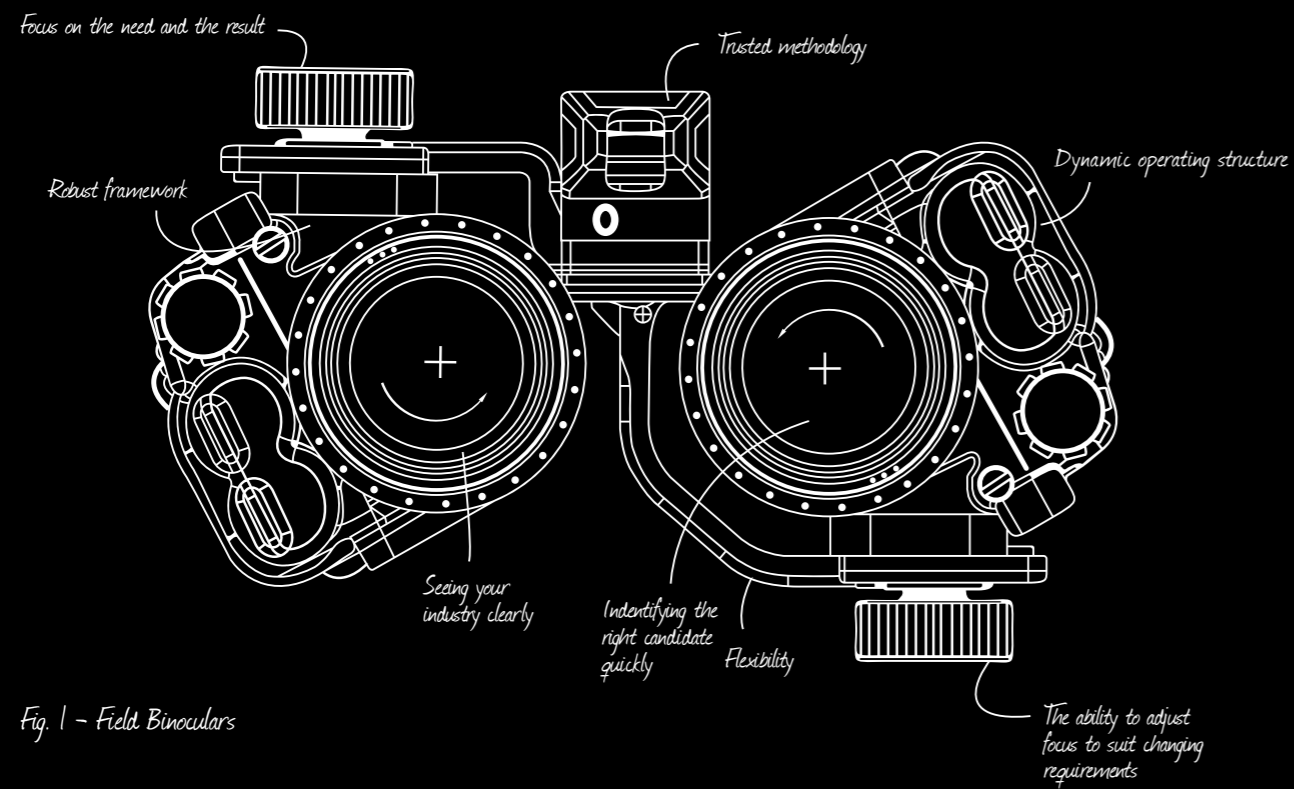

Fig. 1 - Field Binoculars

# WHO ARE GRANGER REIS? ANSWERS INSIDE

DEVELOPED COMPETITIVE ADVANTAGE	02
DRIVEN BY INDEPENDENCE	04
OUR PEOPLE	06
OUR SERVICES	08
SPECIALIST SECTORS	10
TALK TO US	12

Fig. 2 - J Boat 105 Racing Yacht



*Your ambitions are our goals*

We are sector specialists with a deep understanding of our clients' markets. We find the industries' highest performers at board, senior executive and management level; leaders with exceptional track records who will deliver long term, sustainable value for your organisation.

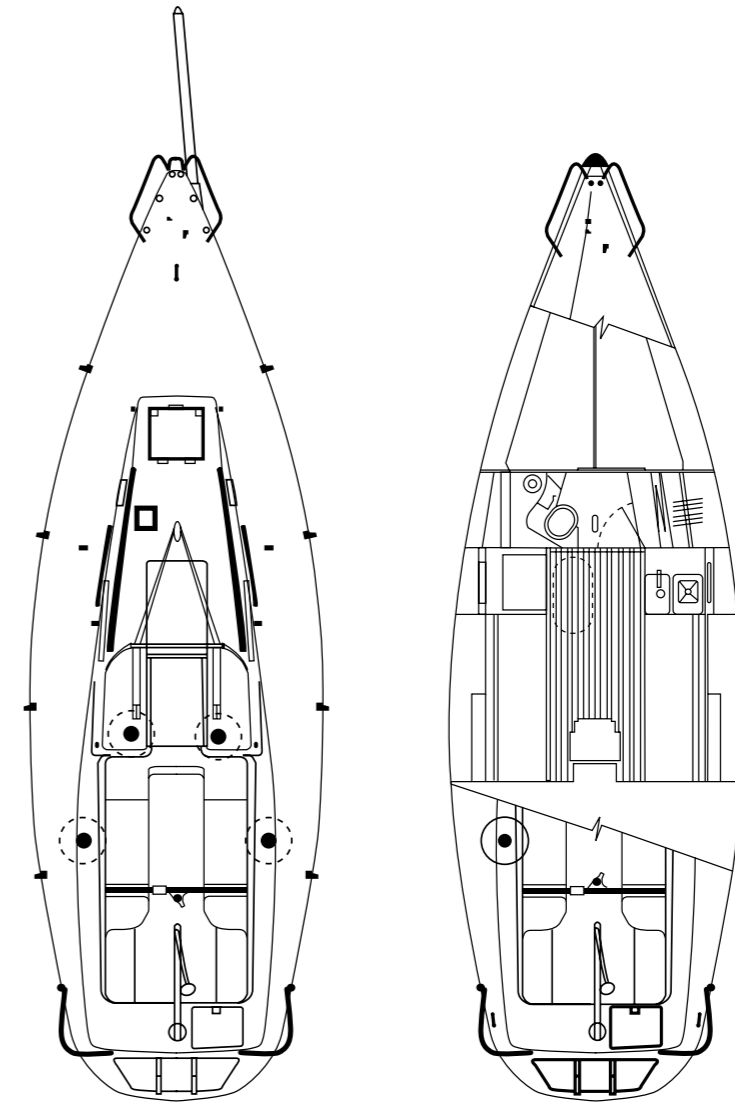
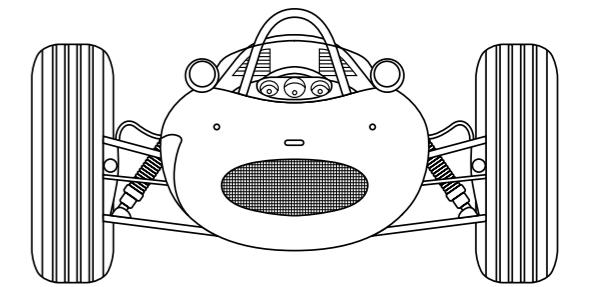
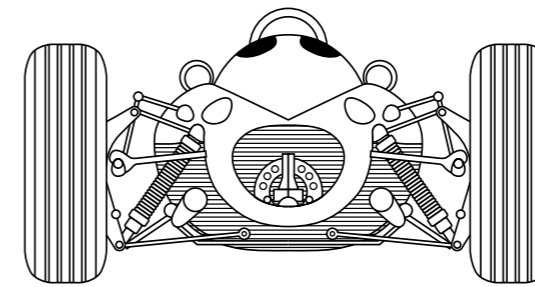
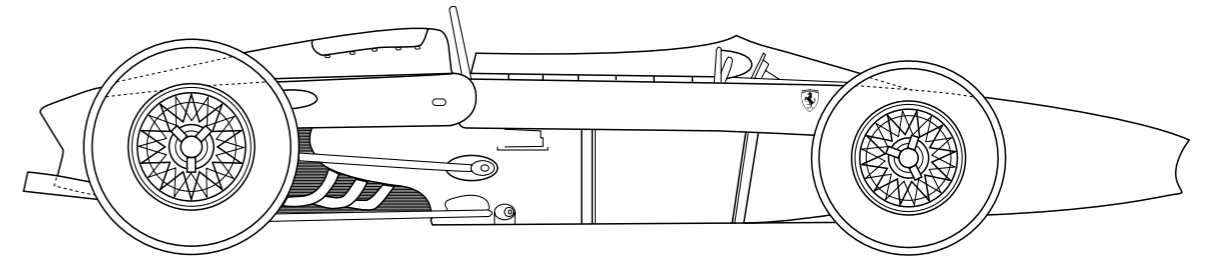
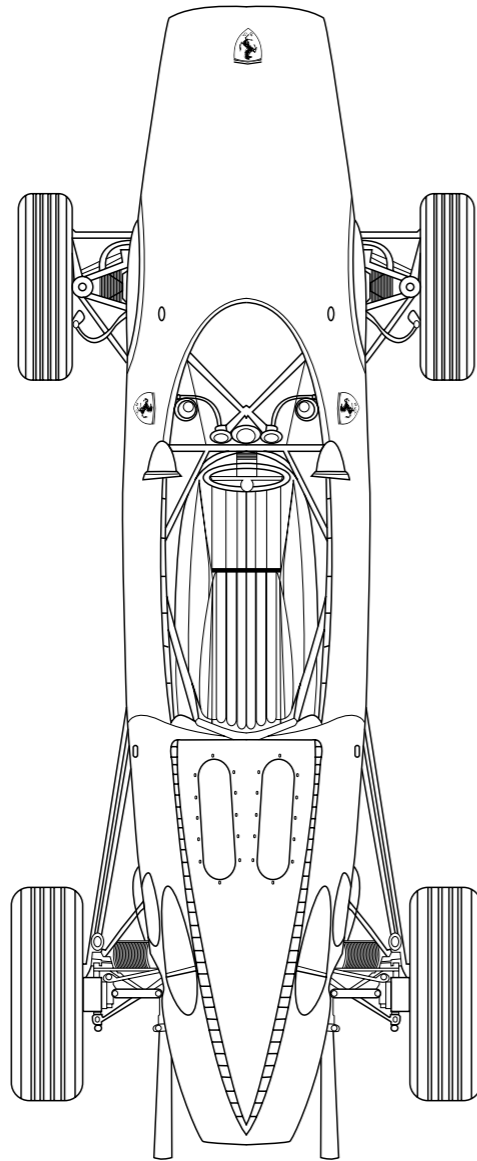

Fig. 3 - J Boat 105 Racing Yacht upper and lower decks

We work across a number of specialist sectors and our clients range from some of the world's largest corporations to medium-sized operations and entrepreneurial start-ups. They choose Granger Reis because we have unparalleled industry expertise, a proven record of delivery and a service that sets us apart from others.

*Fig. 4 - Ferrari 156 V6*



*Driven by our customers*

We are committed to providing a high quality, long-term service. We work in partnership with our clients to better enable us to provide bespoke solutions for their needs.

Our ethos of partnering, plus our commitment to responsible and ethical practice, is made possible by the fact that we are privately owned. Independent of any outside interests and the demands of shareholders, we can place our clients' interests first at all times. This approach has allowed us to forge long term relationships and an unparalleled network. We are engaged for the finest leadership appointments across a broad range of sectors, in the UK and overseas. We are proud of the fact that 90 per cent of our income is derived from repeat business.



*We employ the best to find the best*

Our hand-picked teams represent the finest in the industry. They are focused, energetic, and have in-depth knowledge and experience of their specialist sectors, supported by robust networks of contacts.

Each of our partners and consultants has demonstrable experience of delivering in the markets in which they operate and draws on an understanding of the challenges their clients face and the evolving market environment.

Underpinning everything we do is our research team that combines quality processes with knowledge and understanding of each of our specialist sectors.

Granger Reis is made up of two distinct divisions that will give your organisation the competitive edge:

**1. Search and Selection**

**Executive Search:**

Our Executive Search service assists clients in finding the best person not only for a specific role but for their organisation as a whole. We utilise our extensive network of contacts and industry research to identify candidates and then manage the process from initial briefing through to a post appointment review of the project.

**Advertised Selection:**

Advertised search and selection can still be the most effective route to the hire of senior-level personnel. Where this is the best option, Granger Reis can manage the whole process on your behalf, using a combination of print advertising and executive search.

**Equity Search:**

We work in partnership with start-ups and privately-owned businesses to acquire the best senior talent to strengthen their board of directors. When working with these types of businesses, Granger Reis has experience of structuring equity stake agreements as an alternative to a traditional fee payment.

**Interim:**

Our extensive network of contacts at a senior level enables us to identify candidates able to provide immediate, short-term support which, in turn, can add long-term value to a business. Whether for interim cover for senior positions or for specific short-term fixed contracts, we have an unrivalled network.

**Future Leaders:**

Our market insight, sector experience and extensive networks mean that we are well placed to identify emerging talent to join your organisation today with a view to progressing to more senior positions in the future.

**Tracking:**

We will identify key individuals for a role and track their progress over time until they become available to fill your position.

*Fig. 5 - Field Binoculars - top view*

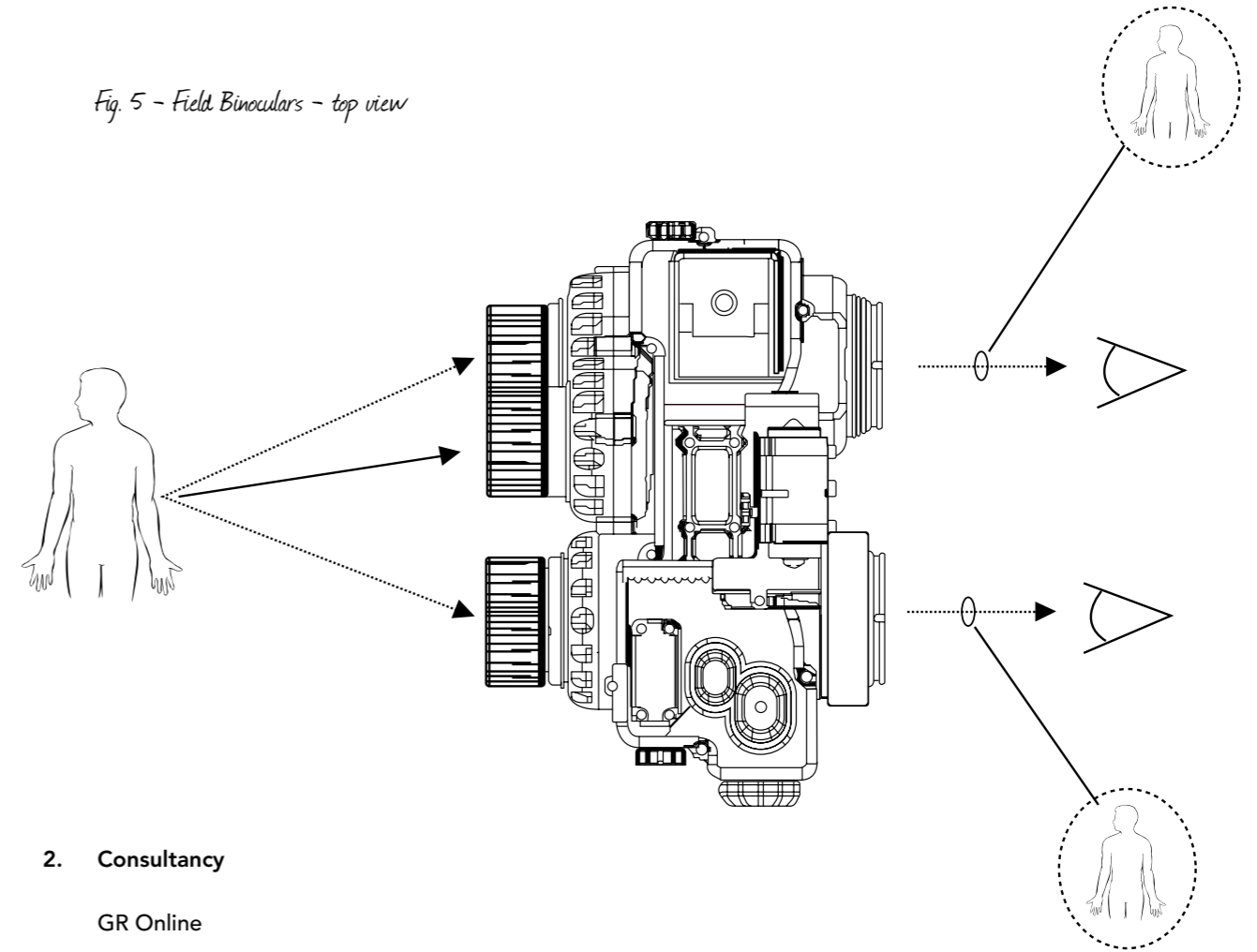

**2. Consultancy**

**GR Online**

GR Online is a division within Granger Reis Consultancy. It provides an online recruitment service to key clients, allowing them to source and recruit candidates from junior to middle management roles at vastly reduced rates.

We work with clients to enable them to:

- Improve the effectiveness of their recruitment systems and their corporate career site
- Improve the overall recruitment process to reduce the amount of time and resources spent
- Engage with candidates online and develop an attractive employer brand
- Target candidates more efficiently and effectively than their competitors

**Research-based consultancy**

We undertake bespoke consultancy and research projects for our clients. We can provide consultation and advice in many areas, including:

- Market appraisals and emerging trends
- Competitor analysis, against which to position a new venture
- Salary surveys
- Staff assessments, to benchmark performance against your competition
- Organisation mapping

Our clients expect a deep knowledge of their industry sectors. For this reason, Granger Reis is organised into specialist practices, each with in-depth industry knowledge, technical expertise and access to leadership networks in their specific markets.

Our unique ability is to understand the entire lifecycle of the industry and the individuals involved within each sector.

**Transport**

- Rail
- Highways
- Aviation
- Logistics
- Marine

*Consultant*



*Manufacturers*



*Contractors*



*Operators*



*Client*

**Built Environment**

- Building
- Infrastructure
- Facilities Management
- House Building
- Building Services
- Regeneration
- Design, Surveying

*Finance*



*Investment*



*Development*



*Professional Services*



*Contracting*



*Support Services*

**Power, Energy**

- Conventional Power
- Nuclear
- Renewable Energy

*Developers*



*Utilities*



*Operators*



*Professional Services*



*Construction*



*Maintenance*

**Natural Resources**

We work with clients who operate across the full life cycle including Exploration and Transportation right through to Refining and Retail.

- Oil & Gas
- Mining & Minerals
- Coal

*Exploration*



*Transportation*



*Refining*



*Retail*

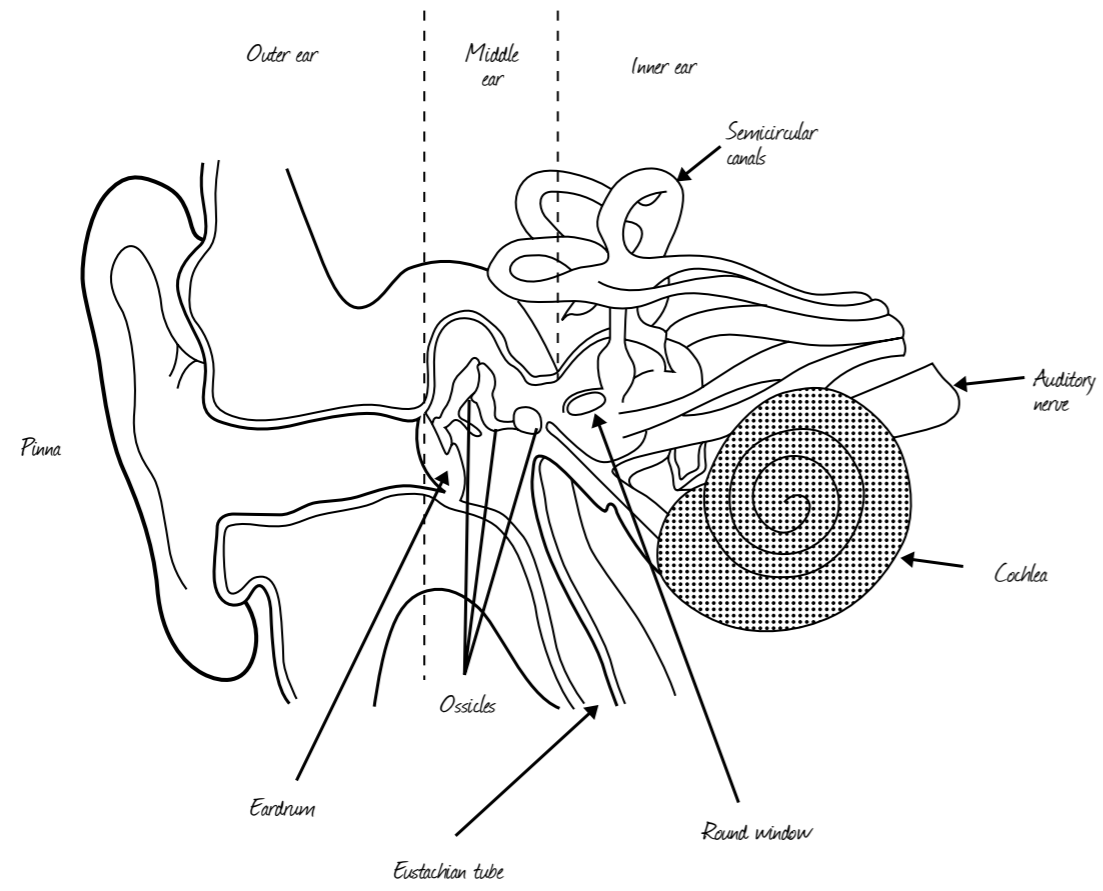

Fig. 6 - Internal diagram of the ear

Head Office | Granger Reis Limited, Vertigo, Cheese Lane, Bristol, BS2 0JJ  
Tel | 0844 800 0799 Fax | 0844 800 0798 Email | info@grangerreis.com  
WWW.GRANGERREIS.COM

GRANGER REIS